

Timing Belt and Belt Tensioner Components

S5RW0D1406050

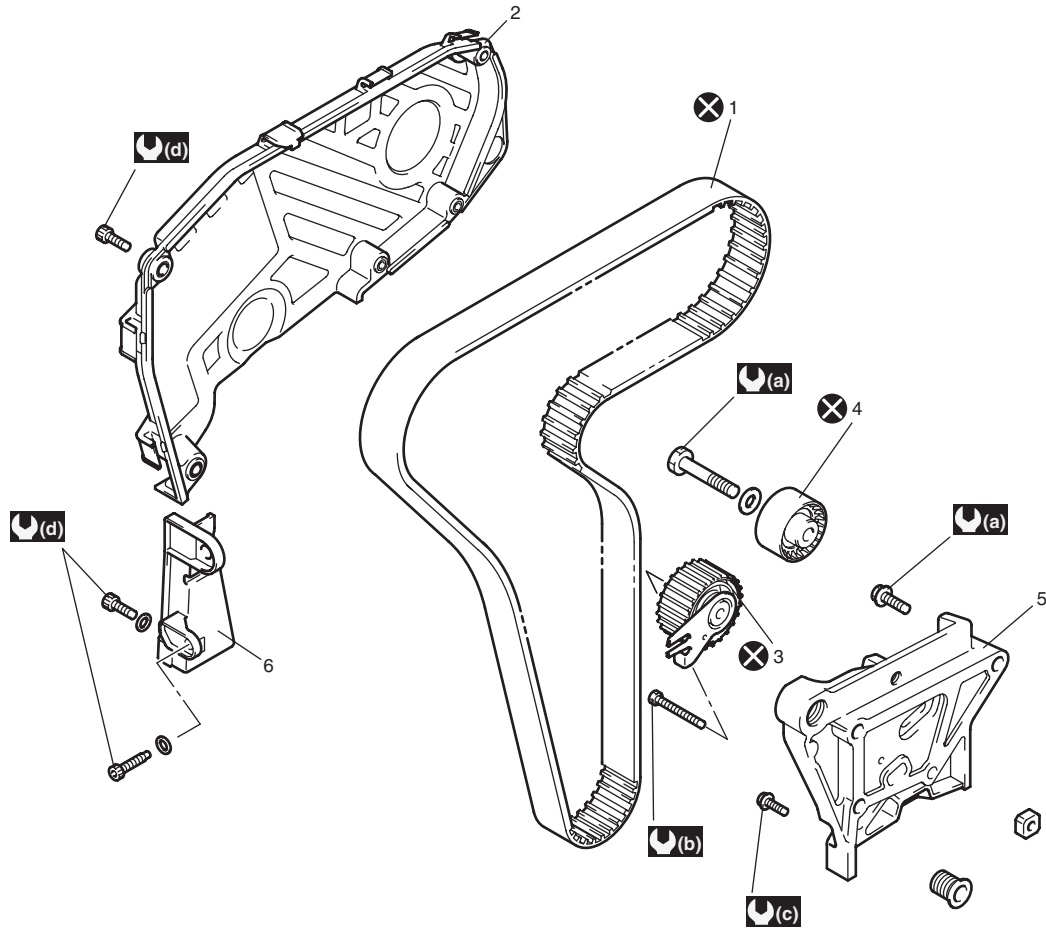

I5RW0D140018-01

1. Timing belt	(a) : 50 N·m (5.0 kgf-m, 36.5 lb-ft)
2. Timing belt cover	(b) : 26 N·m (2.6 kgf-m, 19.0 lb-ft)
3. Timing belt tensioner pulley	(c) : 25 N·m (2.5 kgf-m, 18.0 lb-ft)
4. Timing belt idler pulley	(d) : 9 N·m (0.9 kgf-m, 6.5 lb-ft)
5. Timing belt tensioner support	X : Do not reuse.
6. Timing belt side protective cover	

Timing Belt, Belt tensioner and Idler Removal and Installation

S5RW0D1406084

CAUTION

- Never turn high pressure pump pulley counterclockwise. It may cause damage of high pressure pump.
- After timing belt is removed, never turn crankshaft and camshaft independently. If turned, interference may occur between piston and valves and valves themselves, and parts related to piston and valves may be damaged.
- Do not bend or twist timing belt.
- Do not allow timing belt to come into contact with oil, water, etc. It may be adversely affect belt life.

Removal

- 1) Disconnect negative (-) cable at battery.
- 2) Hoist vehicle and remove front wheel of right side.
- 3) Remove generator drive belt, tensioner and idler pulley referring to "Generator Drive Belt, Tensioner and Idler Pulley Removal and Installation in Section 1J".

4) Remove crankshaft pulley (1).

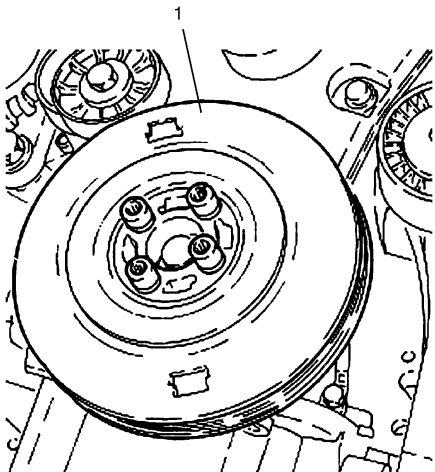

I5RW0D140019-01

5) Remove hood, and support engine assembly as shown in figure by using engine support.

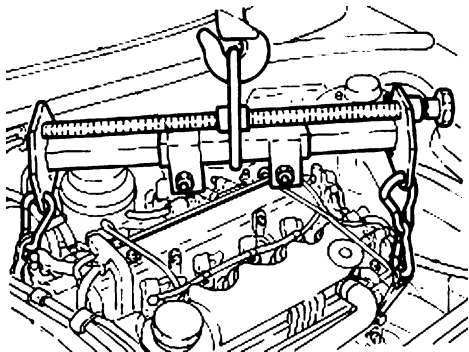

I5RW0D140020-01

6) Remove engine right mounting bracket No.1 (1).

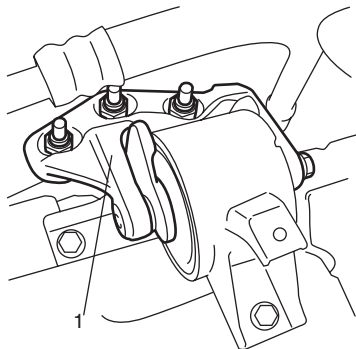

I5RW0D140021-01

7) Remove timing belt cover (1).

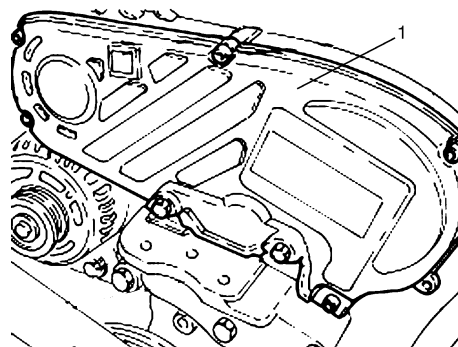

I5RW0D140022-01

8) Remove engine right mounting bracket No.2 (1).

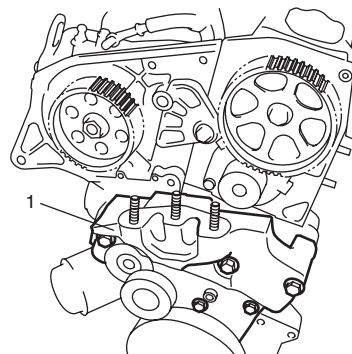

I5RW0D140023-01

9) Align camshaft timing sprocket mark (1) with notch (2) of cylinder head cover by turning crankshaft.

10) Loosen timing belt tensioner bolt (3) and remove timing belt (4).

11) Remove timing belt tensioner (5) and idler pulley (6).

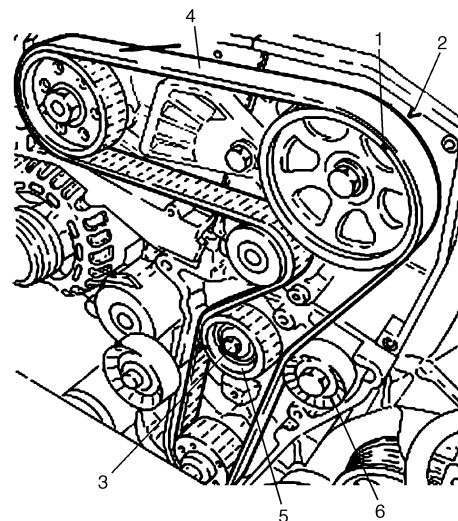

I5RW0D140024-01

Installation

- 1) Check that match mark (1) on camshaft timing sprocket are in match with notch (2) on cylinder head cover as shown in figure.

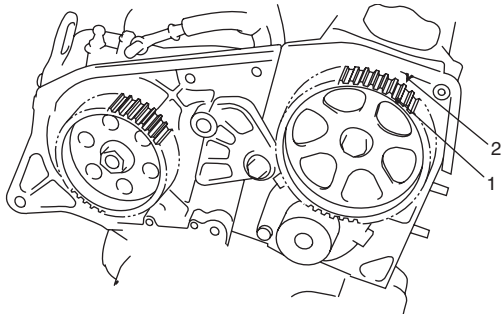

- 2) Match position of crankshaft timing belt pulley as follows.
 - a) Loosen oil pump bolt (1).
 - b) Install special tool to crankshaft timing belt pulley.

NOTE

The crankshaft must be rotated, using small movements, to allow the locating dowel on the toothed timing drive pulley to be inserted in the opening in the tool.

Special tool
(A): 09912-37910

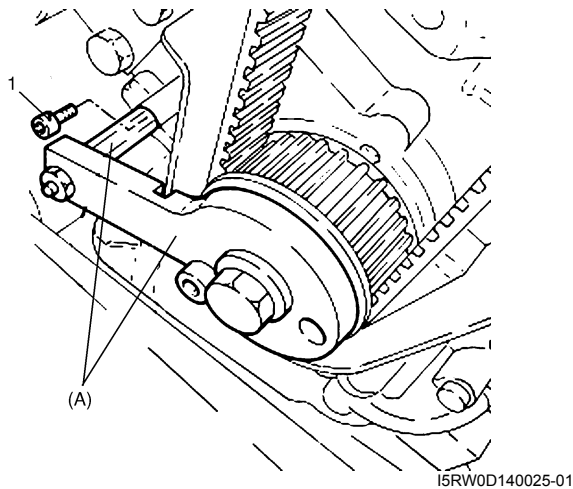

- c) Remove special tool from crankshaft timing belt pulley.

- 3) Install new timing belt idler pulley (1).

Tightening torque

Timing belt idler pulley bolt (a): 50 N·m (5.0 kgf-m, 36.5 lb-ft)

- 4) Install new timing belt tensioner (2) as follows.
 - a) Match grooves (3) of timing belt tensioner and protrusions (4) of timing belt tensioner support.
 - b) Tighten timing belt tensioner bolt (5) by hand.

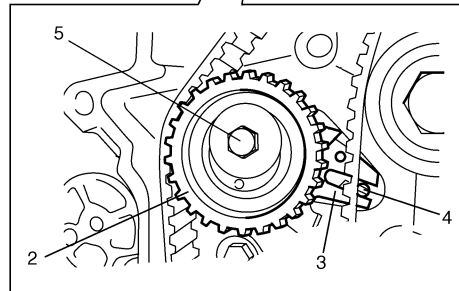
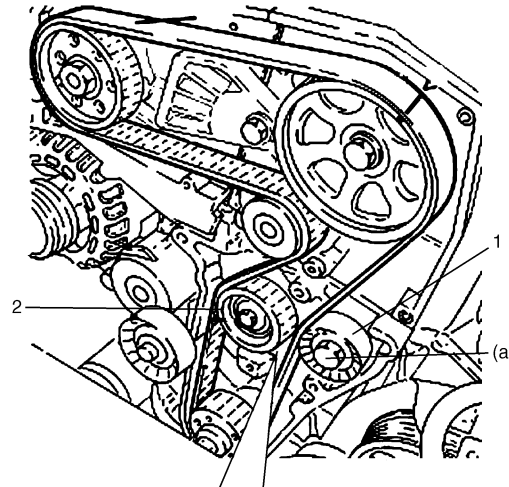

15RW0D140026-01

- 5) Install new timing belt. Match lines (1) of timing belt to match marks (2) on crankshaft timing belt pulley and camshaft timing sprocket.

NOTE

Be sure to direct arrow mark (3) of timing belt clockwise as shown in figure.

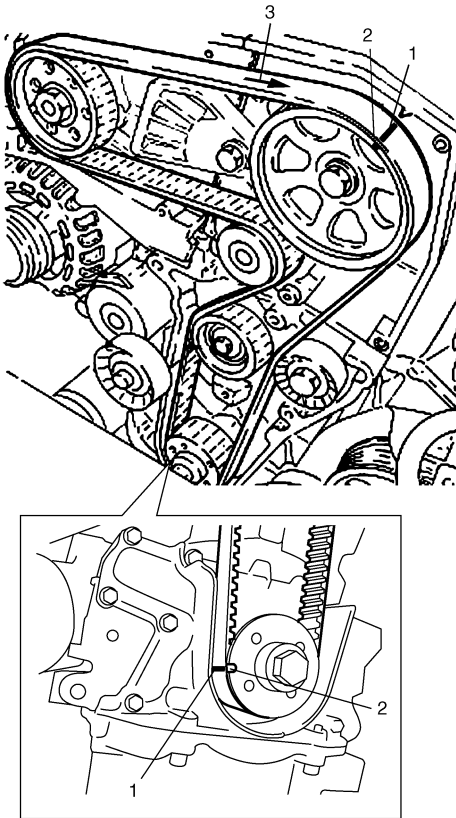

I5RW0D140027-01

- 6) Using screwdriver (3), align movable index (1) of timing belt tensioner (2) to specified position as shown in figure. And then, tighten timing belt tensioner bolt to specified torque.

Tightening torque

Timing belt tensioner bolt (a): 26 N·m (2.6 kgf-m, 19.0 lb-ft)

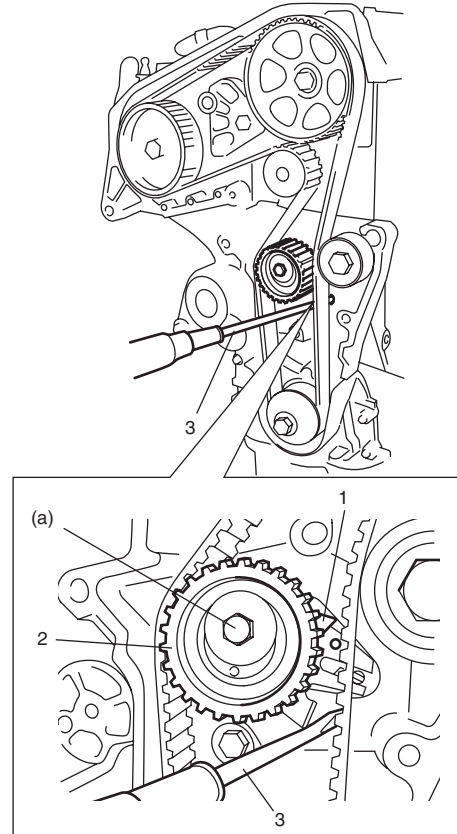

I5RW0D140028-01

- 7) Check match marks of camshaft timing sprocket and cylinder head cover as follows.
- Install special tool to crankshaft timing belt pulley.

NOTE

The crankshaft must be rotated, using small movements, to allow the locating dowel on the toothed timing drive pulley to be inserted in the opening in the tool.

Special tool
: 09912-37910

- Check that match marks on camshaft timing sprocket are in match with notch on cylinder head cover.
- Remove special tool.

- 8) Turn crankshaft two revolutions clockwise.
- 9) Adjust timing belt tension as follows.
 - a) Keep tension of timing belt by using screwdriver (4).
 - b) Loosen timing belt tensioner bolt (2).
 - c) Align movable index (3) of timing belt tensioner (1) to center of match mark (5).
 - d) Tighten timing belt tensioner bolt to specified torque.

Tightening torque

Timing belt tensioner bolt (a): 26 N·m (2.6 kgf-m, 19.0 lb-ft)

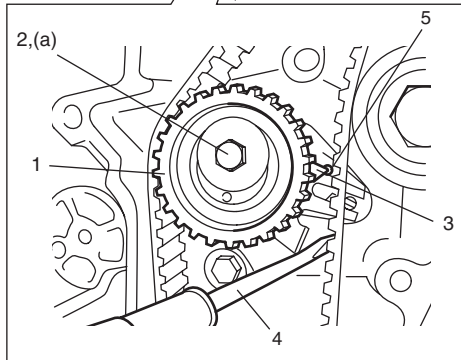
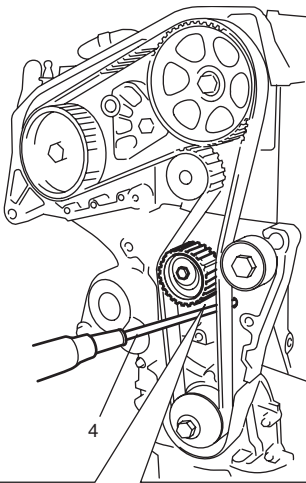

I5RW0D140029-03

- 10) Repeat step 7).
- 11) Tighten new oil pump bolt to specified torque.

Tightening torque
Oil pump bolt: 9 N·m (0.9 kgf-m, 6.5 lb-ft)
- 12) Install engine right mounting bracket No.2 (1), and tighten new engine right mounting bracket No.2 bolts to specified torque.

Tightening torque

Engine right mounting bracket No.2 bolt (M10) (a): 50 N·m (5.0 kgf-m, 36.5 lb-ft)
Engine right mounting bracket No.2 bolt (M8) (b): 25 N·m (2.5 kgf-m, 18.0 lb-ft)

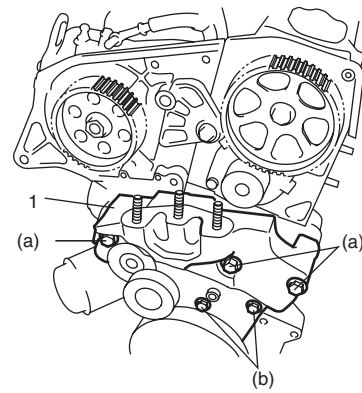

I5RW0D140055-02

- 13) Install timing belt cover.

Tightening torque

Timing belt cover bolt: 9 N·m (0.9 kgf-m, 6.5 lb-ft)

- 14) Install generator drive belt tensioner and idler pulley referring to "Generator Drive Belt, Tensioner and Idler Pulley Removal and Installation in Section 1J".
- 15) Install engine right mounting bracket No.1 referring to "Engine Mounting Components".
- 16) Remove engine support.
- 17) Install crankshaft pulley.

Tightening torque

Crankshaft pulley bolt: 26 N·m (2.6 kgf-m, 19.0 lb-ft)

- 18) Install generator drive belt referring to "Generator Drive Belt, Tensioner and Idler Pulley Removal and Installation in Section 1J".
- 19) Install front wheel of right side and lower hoist referring to "Wheel Removal and Installation in Section 2D in related manual".
- 20) Connect negative (-) cable at battery.
- 21) Install hood referring to "Hood Removal and Installation in Section 9J in related manual".

Timing Belt Inspection

S5RW0D1406052

Timing belt

Inspect timing belt for wear or crack. Replace it as necessary.

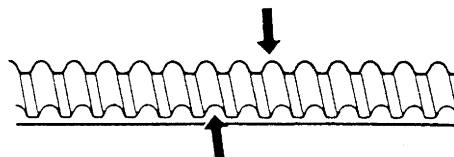

I4RH0A140043-01