

# Engine Electrical Devices

## Repair Instructions

### Engine Control Module (ECM) Removal and Installation

S6RW0C1306001

**⚠ CAUTION**

As ECM consists of precision parts, be careful not to expose it to excessive shock.

**NOTE**

For vehicle equipped with immobilizer control system:  
 If ECM is replaced with new one or with another one, make sure to register immobilizer transponder code to ECM correctly according to "Procedure after ECM Replacement in Section 10C".

#### Removal

- 1) Disconnect negative cable at battery.
- 2) Remove ECM cover.
- 3) Disconnect connectors from ECM as follows.
  - a) Push lock (1) to release locking of lock lever (2).
  - b) Turn lock lever to arrow direction until it stops.

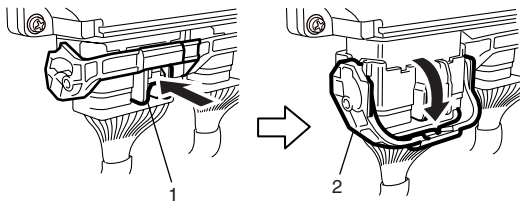

I4RS0A130003-01

- 4) Remove ECM (1) from its bracket by removing its mounting bolts (2).

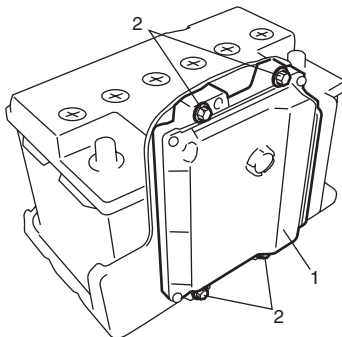

I5RW0A130001-01

#### Installation

Reverse removal procedure noting the following:

- Connect connectors to ECM as follows.
  - a. Make sure that lock lever of ECM connector is unlock position.

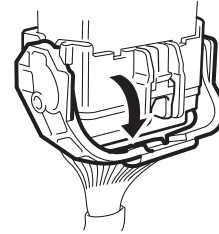

I4RS0B130021-01

- b. Insert ECM connectors to ECM until it stops with unlocked lock lever.

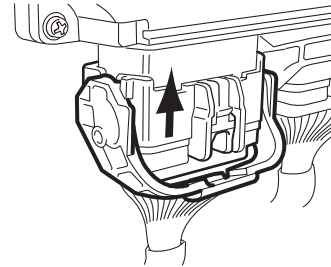

I4RS0B130022-01

- c. Lock ECM connectors securely by pulling its lock lever up.

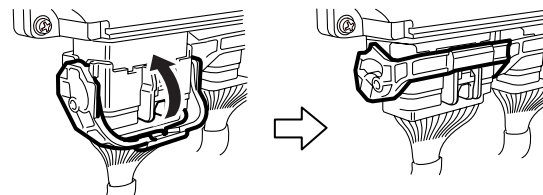

I4RS0A130004-01

## Electric Throttle Body Assembly On-Vehicle Inspection

S6RW0C1306004

### **⚠ WARNING**

Never touch throttle valve with finger while ignition switch is turned ON and accelerator pedal is depressed. Otherwise, injury may result by pinching the finger between throttle valve and throttle body housing.

### **⚠ CAUTION**

- Do not disassemble electric throttle body assembly.
- Do not expose electric throttle body assembly to excessive shock like a dropping it. If electric throttle body assembly has been exposed to excessive shock, it should be replaced.
- Be careful not to accrete a foreign material (like dust and/or metallic particle) to the throttle body housing and/or throttle valve. Otherwise, the throttle body assembly is breaking down by throttle valve accretion.
- Do not apply excessive moving force to throttle valve for throttle valve operation check and/or TP sensor performance check.  
Otherwise, the throttle body assembly is breaking down by damaging the internal resinous gear of throttle valve actuator.

### Throttle Valve Visual Check

- 1) Remove air cleaner outlet hose.
- 2) Check that there isn't any foreign matter caught between throttle valve and throttle body housing. If there is, take it out after removing throttle body referring to "Electric Throttle Body Assembly Removal and Installation in Section 1D" and clean inside of throttle body thoroughly.

### Throttle Valve Operation Check

- 1) Remove air cleaner outlet hose.
- 2) Turn OFF ignition switch.
- 3) Move throttle valve with finger to its full open position and check that it moves smoothly.
- 4) Move throttle valve with finger to its completely closed position and check that it moves smoothly.

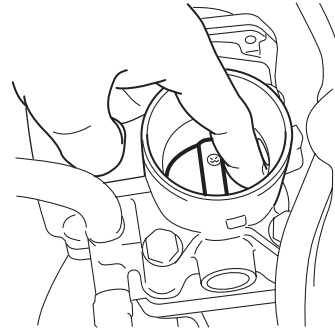

I5JB0A130013-01

- 5) Take off finger from throttle valve (1) which is at full open position and check that it moves smoothly by its return spring and open spring force back to default position (position where throttle valve is open by 7° (2) from completely closed position).
- 6) Take off finger from throttle valve (1) which is at completely closed position and check that it moves smoothly by its return spring and open spring force back to default position.

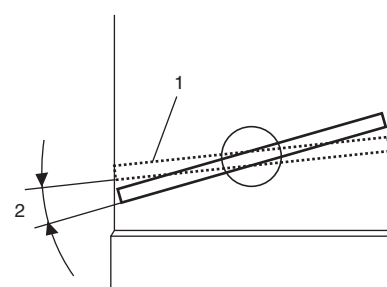

I5JB0A130035-01

If check result is not satisfactory, replace electric throttle body assembly.

**Electric Throttle Body Assembly Operation Check**

- 1) Remove air cleaner outlet hose.
- 2) Turn ON ignition switch.
- 3) Depress accelerator pedal gradually and check that throttle valve moves smoothly until it opens fully.
- 4) Release accelerator pedal depressed in Step 3) and check that throttle valve (1) moves back to default position (position where throttle valve is open by 7° (2) from its completely closed position).

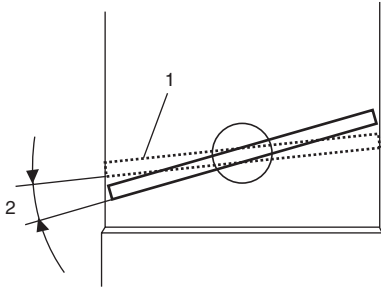

I5JB0A130035-01

If check result is satisfactory, electric throttle body system is in good condition. If check result is not satisfactory, proceed to next step.

- 5) Perform "Accelerator Pedal Position (APP) Sensor Assembly On-Vehicle Inspection", "Throttle Actuator (Motor) Check" and "Throttle Position Sensor Performance Check".

If check results are not satisfactory, replace electric throttle body assembly.

If check results are satisfactory, wire circuit and/or ECM are faulty.

**Throttle Actuator (Motor) Check**

- 1) Turn OFF ignition switch.
- 2) Disconnect connector from electric throttle body assembly.
- 3) Measure resistance between "M1" terminal (1) and "M2" terminal (2) of electric throttle body assembly. If measured resistance is out of specified value, replace electric throttle body assembly.

**Throttle actuator (motor) resistance**  
 0.3 – 100 Ω at 20 °C, 68 °F

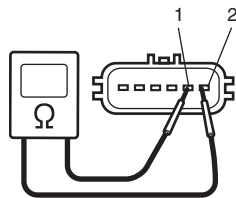

I7RW01130003-01

**Throttle Position (TP) Sensor Performance Check**

- 1) Remove air cleaner outlet hose.
- 2) Turn OFF ignition switch.
- 3) Disconnect connector from electric throttle body assembly.
- 4) Check TP sensor (main and sub) output voltage as the following steps.

- a) For TP sensor (main), arrange 3 new 1.5 V batteries (1) in series (check that total voltage is 4.5 – 5.0 V) and connect its positive terminal to "Vin" terminal (2) and negative terminal to "Ground" terminal (3) of sensor. Then using voltmeter, connect positive terminal to "Vout 1" terminal (4) of sensor and negative terminal to battery.

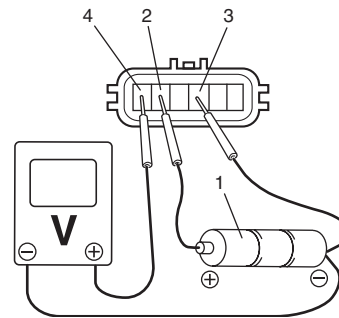

I7RW01130004-01

- b) For TP sensor (sub), arrange 3 new 1.5 V batteries (1) in series (check that total voltage is 4.5 – 5.0 V) and connect its positive terminal to "Vin" terminal (2) and negative terminal to "Ground" terminal (3) of sensor. Then using voltmeter, connect positive terminal to "Vout 2" terminal (4) of sensor and negative terminal to battery.

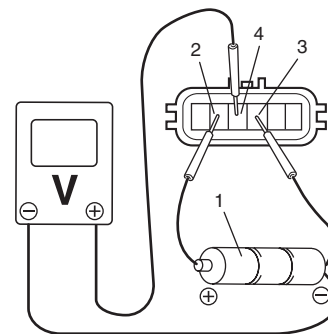

I7RW01130005-01

- c) Measure output voltage variation while throttle valve is opened and closed as the following specification.

If sensor voltage is out of specified value and linear variation as the following graph, replace electric throttle body assembly.

**TP sensor output voltage**

**TP sensor (main) [A]: 0.45 – 4.88 V, varying according to throttle valve opening by finger (Voltage should vary by 0.04 V for each 1° valve opening)**

**TP sensor (sub) [B]: 1.33 – 5.007 V, varying according to throttle valve opening by finger (Voltage should vary by about 0.032 V for each 1° valve opening)**

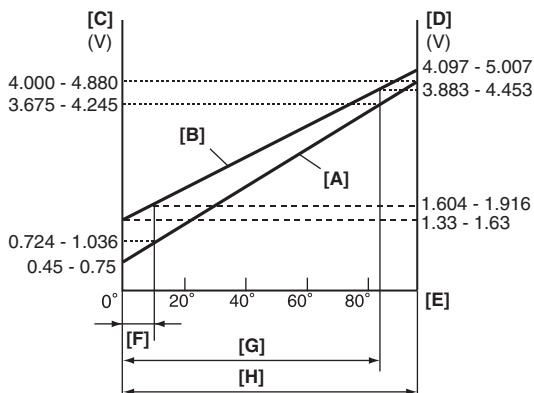
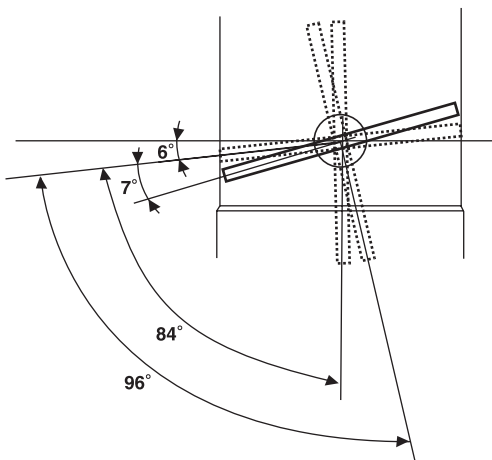

I7RW01130019-05

[C]: TP sensor (main) output voltage
[D]: TP sensor (sub) output voltage
[E]: Throttle valve opening
[F]: Position where throttle valve is open by 7° from completely closed position (default position)
[G]: Angle obtained when accelerator pedal is depressed fully (84°)
[H]: Angle obtained when throttle valve is fully opened with finger (96°)

### Electric Throttle Body System Calibration

S6RW0C1306005

#### NOTE

**If the service described under the “Precautions of Electric Throttle Body System Calibration in Section 1A” is performed, calibrate electric throttle body system as follows.**

- 1) If electric throttle body assembly and/or APP sensor assembly are replaced, perform the following steps.
  - a) Disconnect negative cable at battery for 20 seconds or more for the purpose of clearing calibration data of closed throttle position from memory in ECM.
  - b) Connect negative cable to battery.
- 2) Keep ignition switch at ON position for 5 seconds or more without running engine.

### Accelerator Pedal Position (APP) Sensor Assembly On-Vehicle Inspection

S6RW0C1306006

- 1) Check that APP sensor assembly has been mounted to vehicle body properly (no pinched floor carpet, etc.).  
If mounting is not properly, reinstall APP sensor assembly properly referring to “Accelerator Pedal Position (APP) Sensor Assembly Removal and Installation”.
- 2) Connect scan tool to DLC with ignition switch turned OFF.
- 3) Turn ON ignition switch and select “Data List” mode on scan tool.
- 4) Check that APP sensor voltage varies as the following graph.  
If sensor voltage is out of specified value or does not vary linearly as the following graph, check APP sensor assembly referring to “Accelerator Pedal Position (APP) Sensor Assembly Inspection”.

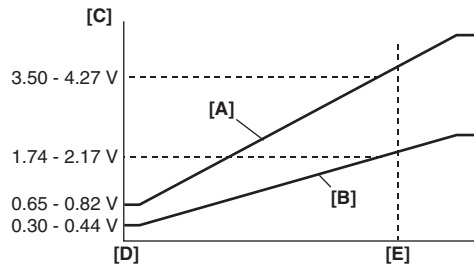
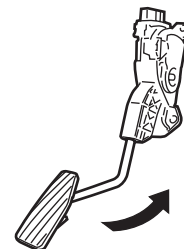

I7RW01130020-01

[A]: APP sensor (main) voltage
[B]: APP sensor (sub) voltage
[C]: Voltage
[D]: Idle position of accelerator pedal
[E]: Full depressed position of accelerator pedal

## Accelerator Pedal Position (APP) Sensor Assembly Removal and Installation

S6RW0C1306007

### ⚠ CAUTION

- Do not expose APP sensor assembly to excessive shock like a dropping it. If APP sensor assembly has been exposed to excessive shock, it should be replaced.
- Be careful not to expose sensor section of APP sensor assembly to water.

### NOTE

After replacing APP sensor assembly, perform calibration of throttle valve referring to "Electric Throttle Body System Calibration".

### Removal

- 1) Disconnect negative cable at battery.
- 2) Disconnect connector from APP sensor assembly.
- 3) Remove APP sensor assembly from its bracket.

### Installation

Reverse removal procedure for installation noting the following.

- Tighten APP sensor assembly upper nut (1) first and then lower nuts (2) to specified torque.

### Tightening torque

APP sensor assembly nut (a): 6 N·m (0.6 kgf·m, 4.5 lb-ft)

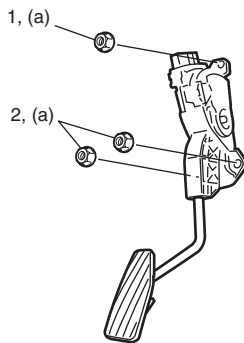

I5RW0A130004-01

- Connect connector to APP sensor assembly securely.

## Accelerator Pedal Position (APP) Sensor Assembly Inspection

S6RW0C1306008

Check APP sensor (main and sub) output voltage as the following steps.

- 1) For APP sensor (main), arrange 3 new 1.5 V batteries (1) in series (check that total voltage is 4.5 – 5.0 V) and connect its positive terminal to "Vin 1" terminal (2) and negative terminal to "Ground 1" terminal (3) of sensor. Then using voltmeter, connect positive terminal to "Vout 1" terminal (4) of sensor and negative terminal to battery.

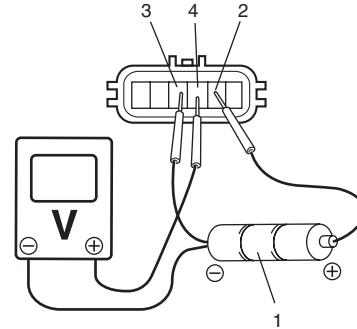

I5RW0A130005-01

- 2) For APP sensor (sub), arrange 3 new 1.5 V batteries (1) in series (check that total voltage is 4.5 – 5.0 V) and connect its positive terminal to "Vin 2" terminal (2) and negative terminal to "Ground 2" terminal (3) of sensor. Then using voltmeter, connect positive terminal to "Vout 2" terminal (4) of sensor and negative terminal to battery.

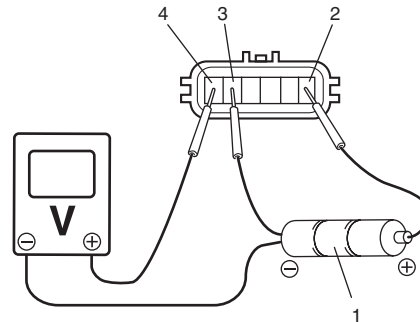

I5RW0A130006-02

- 3) Measure output voltage variation while accelerator pedal is released and fully depressed as the following graph.  
 If sensor voltage is out of specified value or does not vary linearly as the following graph, replace APP sensor assembly.

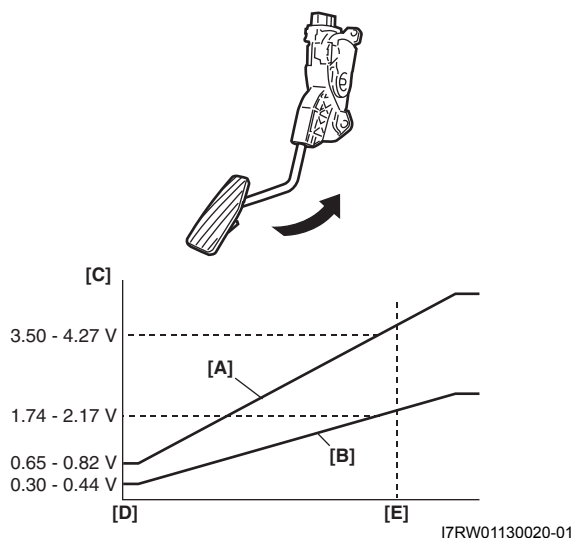

[C]: Voltage
[D]: Idle position of accelerator pedal
[E]: Fully depressed position of accelerator pedal

### Engine Coolant Temperature (ECT) Sensor Removal and Installation

S6RW0C1306009

#### Removal

- 1) Disconnect negative cable at battery.
- 2) Drain coolant referring to "Cooling System in Section 1F".

#### ▲ WARNING

**To avoid danger of being burned, do not remove radiator cap while engine and radiator are still hot. Scalding fluid and steam can be blown out under pressure if cap is taken off too soon.**

- 3) Disconnect connector from ECT sensor (1).

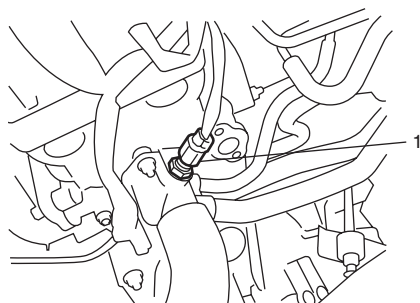

- 4) Remove ECT sensor from water outlet cap.

### Installation

Reverse removal procedure noting the following.

- Clean mating surfaces of ECT sensor and water outlet cap.
- Check O-ring for damage and replace, if necessary.
- Tighten ECT sensor (1) to specified torque.

#### Tightening torque

**ECT sensor (a): 12.5 N·m (1.25 kgf·m, 9.0 lb·ft)**

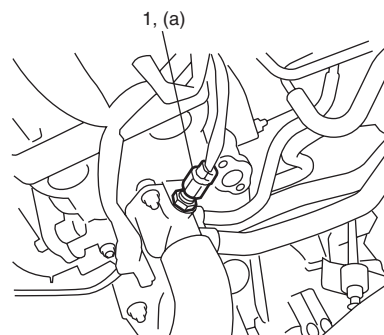

- Connect connector to ECT sensor securely.
- Refill coolant referring to "Cooling System Flush and Refill in Section 1F".

### Engine Coolant Temperature (ECT) Sensor Inspection

S6RW0C1306010

Immerse temperature sensing part of ECT sensor in water (or ice) and measure resistance between sensor terminals while heating water gradually. If measured resistance doesn't show such characteristic as shown, replace ECT sensor.

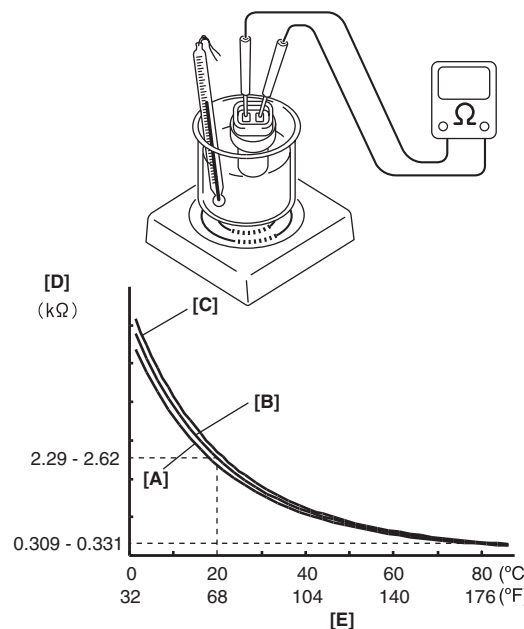

[A]: Lower limit	[D]: Resistance
[B]: Normal	[E]: Temperature
[C]: Upper limit	