

Repair Instructions

Steering Wheel and Column Construction

S6RW0C6206001

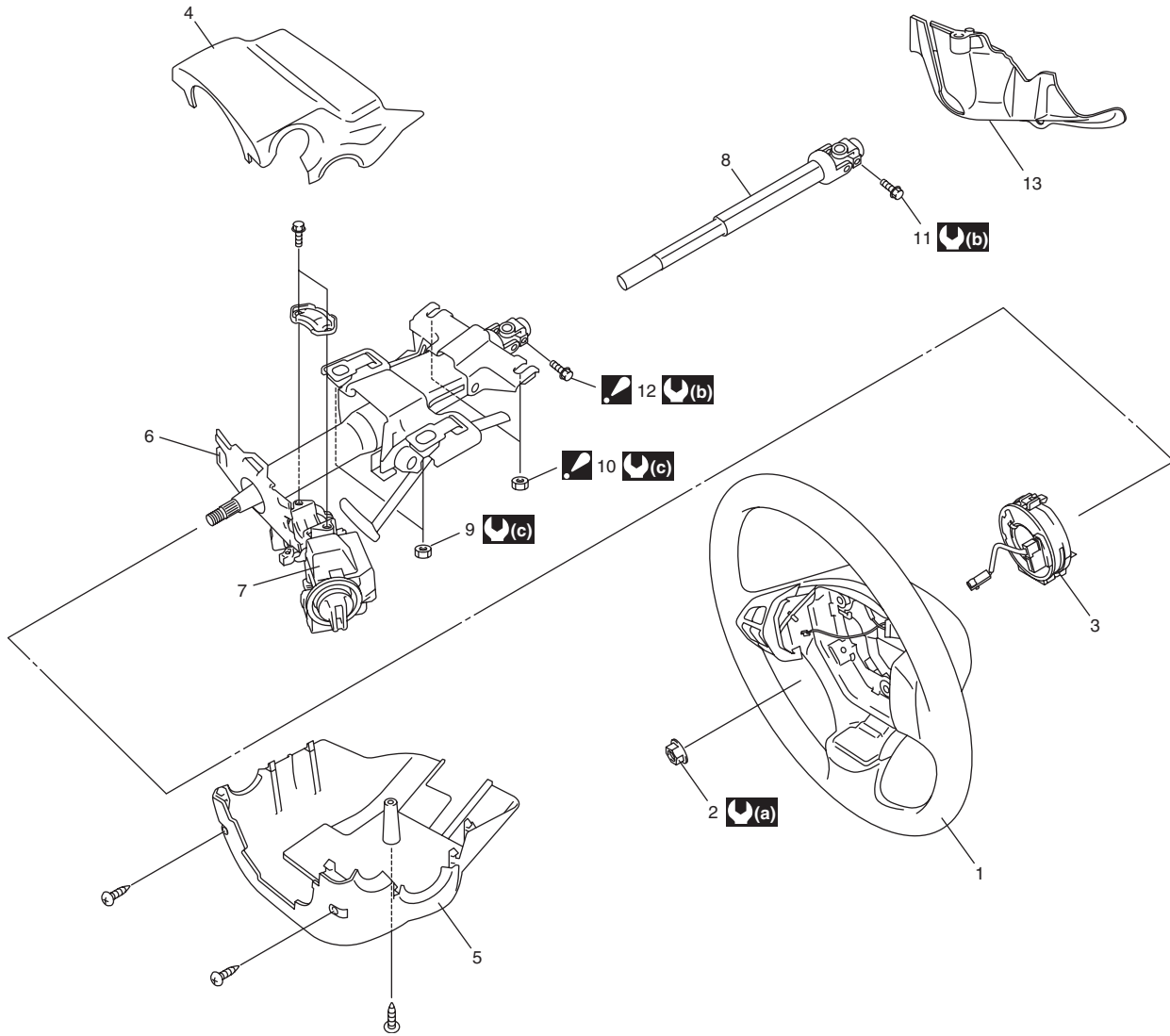

I6RW0C620001-01

1. Steering wheel	9. Steering column assembly mounting nut No.1
2. Steering shaft nut	10. Steering column assembly mounting nut No.2 : After tightening column mounting nut No.2, tighten column mounting nut No.1.
3. Contact coil cable assembly	11. Steering lower shaft assembly lower joint bolt
4. Steering column upper cover	12. Steering lower shaft assembly upper joint bolt : After tightening all column mounting nuts and lower shaft lower joint bolt, tighten lower shaft upper joint bolt.
5. Steering column lower cover	13. Steering joint cover
6. Steering column assembly	: 33 N·m (3.3 kgf·m, 24.0 lb·ft)
7. Steering lock assembly	: 25 N·m (2.5 kgf·m, 18.0 lb·ft)
8. Steering lower shaft assembly	: 14 N·m (1.4 kgf·m, 10.5 lb·ft)

Steering Wheel Removal and Installation

S6RW0C6206002

⚠ CAUTION

Do not turn the contact coil more than allowable number of turns (about two and a half turns from the center position clockwise or counterclockwise respectively) with steering wheel removed, or coil will break.

Removal

⚠ CAUTION

Do not hammer the end of the shaft. Hammering it will loosen the plastic shear pins which maintain the column length and impair the collapsible design of the column.

- 1) Disconnect negative (-) cable at battery.
- 2) Disable air bag system referring to "Disabling Air Bag System in Section 8B".
- 3) Remove driver air bag (inflator) module from steering wheel. Refer to "Driver Air Bag (Inflator) Module Removal and Installation in Section 8B".
- 4) Disconnect horn connector and audio control switch connector, if equipped.
- 5) Remove steering shaft nut and then make alignment marks (1) on steering wheel and shaft for a guide during reinstallation.

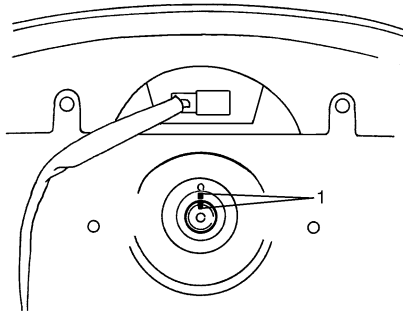

I4RS0A620005-01

- 6) Remove steering wheel using special tool.

Special tool

(A): 09944-36011

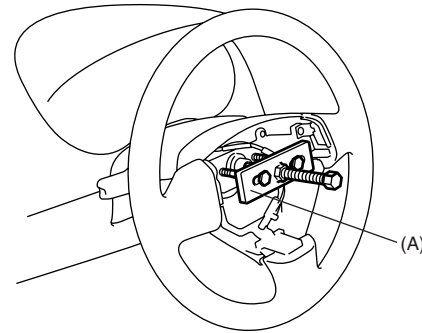

I4RS0A620006-01

Installation

⚠ CAUTION

Following 2 Steps (Step 1) and 2)) are prerequisite for installation of steering wheel. If steering wheel has been installed without these 2 Steps, contact coil will break when steering wheel is turned.

- 1) Check that vehicle's front tires are at straight-ahead position and contact coil is centered. If contact coil is turned after removing steering wheel, center contact coil referring to "Centering Contact Coil Cable Assembly".
- 2) Install steering wheel to steering shaft with 2 grooves (1) on contact coil fitted in 2 lugs (2) in the back of steering wheel and also aligning marks (3) on steering wheel and steering shaft.
- 3) Tighten steering shaft nut (4) to specified torque.

Tightening torque

Steering shaft nut (a): 33 N·m (3.3 kgf-m, 24.0 lb-ft)

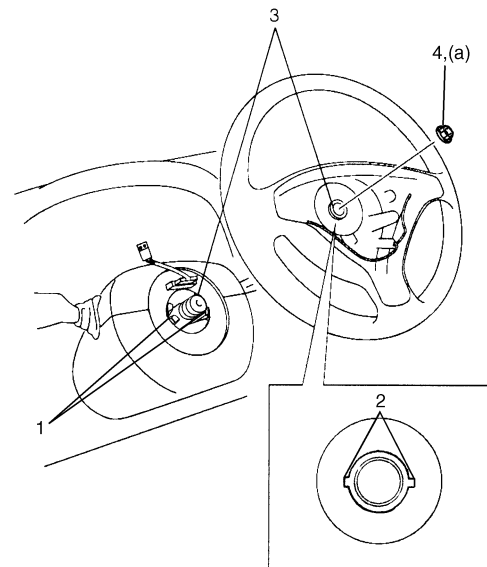

I4RS0A620007-01

6B-5 Steering Wheel and Column:

- 4) Connect horn connector and audio control switch connector, if necessary.
- 5) Install driver air bag (inflator) module to steering wheel. Refer to "Driver Air Bag (Inflator) Module Removal and Installation in Section 8B".
- 6) Connect negative (-) cable to battery.
- 7) Enable air bag system referring to "Enabling Air Bag System in Section 8B".

Contact Coil Cable Assembly Removal and Installation

S6RW0C6206003

⚠ CAUTION

Do not turn contact coil more than allowable number of turns (about two and a half turns from the center position clockwise or counterclockwise respectively), or coil will break.

Removal

- 1) Disconnect negative (-) cable at battery.
- 2) Disable air bag system referring to "Disabling Air Bag System in Section 8B".
- 3) Remove steering wheel from steering column referring to "Steering Wheel Removal and Installation".
- 4) Remove steering column hole cover.
- 5) Remove steering column lower cover (2) and upper cover (1).

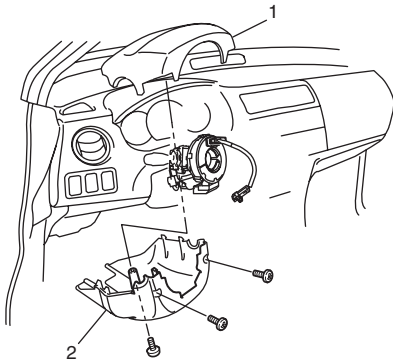

I6RW0B620005-01

Edited by Foxit PDF Editor
Copyright (c) by Foxit Software Company, 2004
For Evaluation Only.

- 6) Remove contact coil cable assembly (1) from steering column.

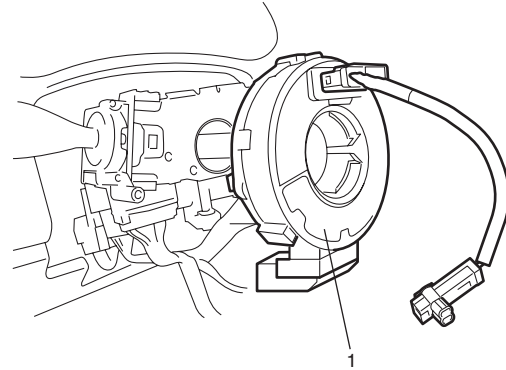

I6RW0B620009-02

Installation

- 1) Check to make sure that vehicle's front tires are set at straight-ahead position and then ignition switch is at LOCK position.
- 2) Install contact coil cable assembly to steering column securely.

NOTE

New contact coil cable assembly is supplied with contact coil set and held at its center position with a lock pin (1). Remove this lock pin after installing contact coil cable assembly to steering column.

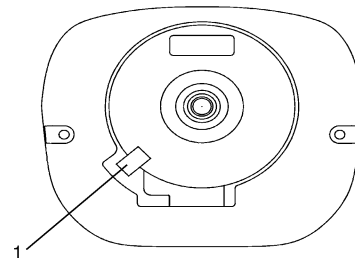

I4RS0A620010-01

- 3) Install steering column upper cover (1) and lower cover (2).

CAUTION

When installing covers, be careful so that each lead wire is not caught between covers. Otherwise, each lead wire is damaged.

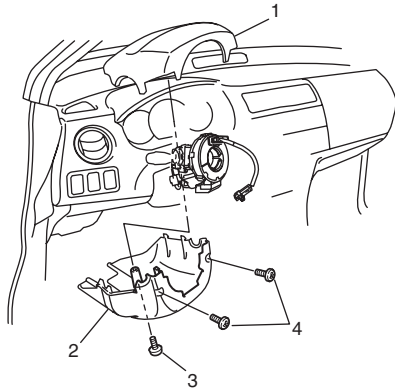

I6RW0B620003-01

3. Standard screw	4. Tapping screw
-------------------	------------------

- 4) Install steering wheel to steering column. Refer to "Steering Wheel Removal and Installation".
- 5) Connect negative (-) cable to battery.
- 6) Enable air bag system referring to "Enabling Air Bag System in Section 8B".

Centering Contact Coil Cable Assembly

S6RW0C6206004

- 1) Check that vehicle's wheels (front tires) are set at straight-ahead position.
- 2) Check that ignition switch is at LOCK position.
- 3) Turn contact coil counterclockwise slowly with a light force till contact coil will not turn any further.

NOTE

Contact coil can turn about 5 turns at the maximum, that is, if it is at the center position, can turn about two and a half turns both clockwise and counterclockwise.

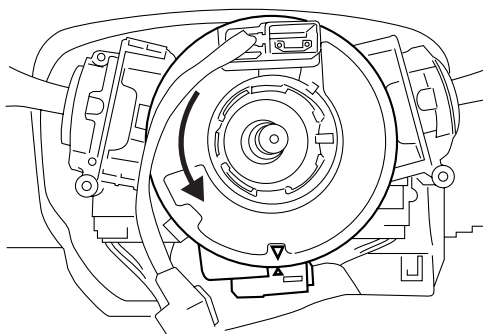

I4RS0A620012-01

- 4) From the position where contact coil became unable to turn any further (it stopped), turn it back clockwise about two and a half rotations and align center mark with alignment mark (1).

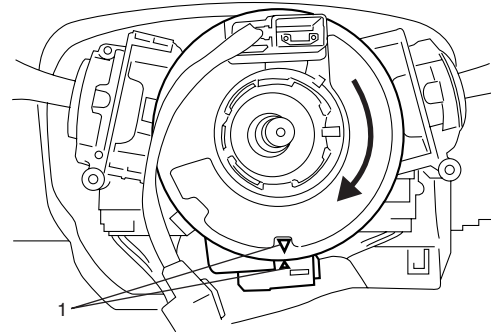

I4RS0A620013-01

Contact Coil Cable Assembly Inspection

S6RW0C6206005

Refer to "Contact Coil Cable and Its Circuit Check in Section 8B".

Steering Column Removal and Installation

S6RW0C6206008

CAUTION

Once the steering column is removed from the vehicle, the column is extremely susceptible to damage.

- Dropping the column assembly on its end could collapse the steering shaft or loosen the plastic shear pins which maintain column length.
- Leaning on the column assembly could cause it to bend or deform.

Any of the damage could impair the column's collapsible design.

Steering column mounting nuts should not be loosened with steering shaft joint upper side bolt tightened as this could cause damage to shaft joint bearing.

NOTE

When servicing steering column or any column-mounted component, remove steering wheel. But when removing steering column simply to gain access to instrument panel components, leave steering wheel installed on steering column.